

## Hybrid Bracket (L-shape) - Steel



### Features

- ▶▶ Surface or concealed mounting for floating shelf appearance
- ▶▶ Available with 12, 18, and 24" support arms
- ▶▶ Texture powder coated finish in black or white
- ▶▶ Non-handed
- ▶▶ Vertical tubular arm: 1-1/2" (width) x 3/4" (thickness)
- ▶▶ Horizontal arm (T-shape): 1-1/2" x 1-1/2"
- ▶▶ Load rate per pair: 1,050 to 2,200 lbs.
- ▶▶ Packaging: 2 bracket per box
- ▶▶ Multiple mounting holes on support arm and vertical tube
- ▶▶ Mounting hardware not included

### Applications

- ▶▶ Counter tops
- ▶▶ Work surfaces
- ▶▶ Shelving (floating)
- ▶▶ ADA access
- ▶▶ Training rooms
- ▶▶ Benches

Surface Mounting



Concealed Mounting



Finishing Caps



Plastic finishing caps in matching color to conceal the bottom of tube (2) and the mounting screw holes (1) are included.

Mounting Detail



Concealed applications require ripping a 2" x 4" lengthwise, and mounting the ripped 2" x 4" (2) to the side of a standard 2" x 4" (1) stud. Bracket is then mounted to the recessed (ripped) 2" x 4". Install drywall around support arm.

Drywalled



Dimensions

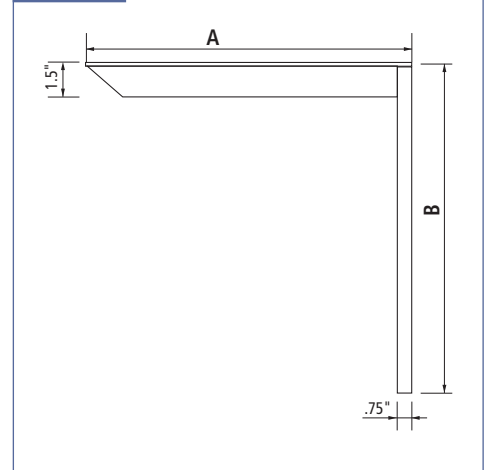

Item Number	A Support Arm		Height B		Load Rating (pair)		Finish
	inch	mm	inch	mm	lbs	kg	
72531 80 212	12	305	12	305	2,050	930	Black
72531 82 215	12	305	12	305	2,050	930	White
72531 80 213	18	457	18	457	1,780	807	Black
72531 82 216	18	457	18	457	1,780	807	White
72531 80 214	24	609	24	609	1,360	617	Black
72531 82 217	24	609	24	609	1,360	617	White