

HINGE OPEN 180°

NO.	QTY.	PART NAME	MATERIAL
1	2	HINGE BODY	ZAMAK NO.3
2	1	BACK PLATE	STEEL
3	1	SLIDE	STEEL
4	2	FLAT HEAD SCREW	STEEL
5	1	SPRING	STEEL
6	1	CAP SCREW	STEEL
7	1	RETAINER	STEEL
8	1	GUIDE TUBE	STEEL
9	12	LINK	STEEL
10	8	LINK	NYLON 6/6
11	2	SHORT ROLLER	NYLON 6/6
12	2	LONG ROLLER	NYLON 6/6
13	1	SPACER	NYLON 6/6
14	1	RISET PIN	STEEL
15	2	LONG PIN	STEEL
16	1	CHANNEL PIN	STEEL

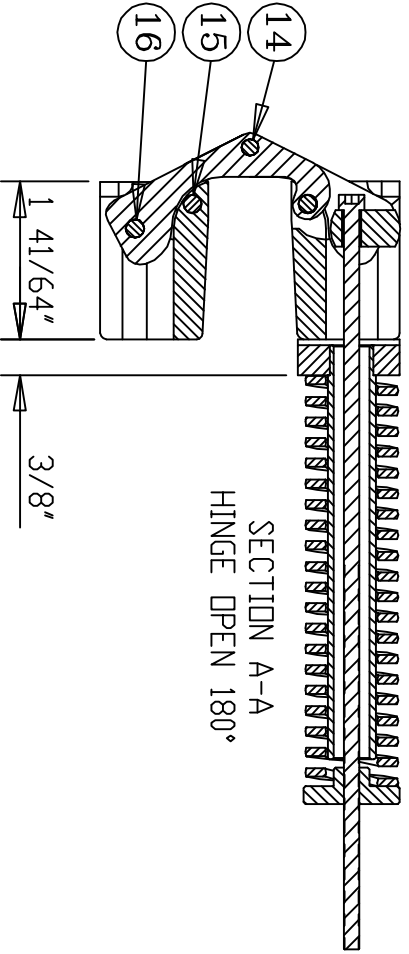

SUPPLIED:

WOOD SCREW MACHINE SCREW
#10 x 1-1/2" #10-24 X 1"

DO NOT SCALE DRAWING
ALL DIMENSIONS ARE IN INCH
MIN. MATERIAL THICKNESS IS 1-3/4"
FOR BODY DIMENSIONS SEE #218FR HINGE TEMPLATE DRAWING

B	5/7/15	ADDED GUIDE TUBE	LHH
A	5/12/13	REDRAWN	SRD
REV	DATE	DESCRIPTION	BY
 ©Copyright Universal Industrial Products, Inc. One Coreway Drive Pioneer, Ohio 43554-0628		SCALE: 1/2 = 1	DRAWN BY: LHH
SELF-CLOSING HINGE TEMPLATE		DATE: 10/15/18	
#218IC SELF-CLOSING SSSS INVISIBLE HINGE		DRAWING # 218	IC